

General Description

ELS27 is a patented smart optical device, which is usually combined with a hydraulic cylinder. The main applications are on double axis steering cylinders, to detect when the 4 wheels are correctly aligned or on stabilizers, to detect when the cylinder is all in. The alignment occurs when the sensor detects a different refraction index zone, which is marked on the hydraulic cylinder's rod with state-of-the-art marking systems.

The product is based on reflective sensor as input stage, a computing unit (microprocessor device) and an output stage with high side driver, which is limited to 20mA, due to the very small size of the sensor. In fact, the ELS27 is on the same package of the standard sensor ELS21, but it has the advantage of full redundancy.

The sensor includes "smart" functions and special algorithms, that allow to continuously adapt to the wear of the system during the time, improving the lifetime and at high reliability (MTTF = 145 years). The adaptive algorithm is the goal to work also in the harsh environment (temperature variations, rod wear, presence of electromagnetic disturbs, presence of humidity, shocks and vibrations).

Applications

- Limit switch for safety functions
- Aerial platforms: position detection
- Telescopic cylinders: limit switch
- Multiple position detection

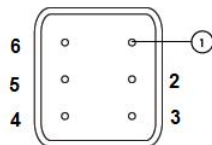

Output diagram, connector Amphenol AT04-6P-MM01



Features

- Fully redundant structure
- Insensitive to EM noise
- High MTTF : 145 years
- Meets all ISO 7637-2 and ISO16750-2 requirements at 12V, Load Dump max levels
- Compact size (same size as 1 channel device)
- Smart interface and smart algorithm
- IP67
- Inversion of polarity and overload protections

Pin Functions

ELS27

No.	Name	Function
1	GND1 (black 1)	Ground 1
2	V _{CC1} (black 2)	Power Supply 1
3	OUT1 (black 3)	Output 1 (PNP) active HIGH
4	OUT2 (black 4)	Output 2 (PNP) active LOW
5	V _{CC2} (black 5)	Power Supply
6	GND2 (yellow/green)	Ground

Ordering Information

ELS27-12AT 12V version, 0.5m cable, AT04-6P connector

ABSOLUTE MAXIMUM RATINGS

Symbol	Parameter	Min	Max	Unit
T _s	Storage Temperature	-40	85	°C
T _A	Operating Temperature Range	-20	80	°C
V _{CC}	Supply Voltage Range OIS27-12AT	7	15	V
I _o	Max output current (depending on ambient temperature)	-	20	mA

Stresses beyond those listed under “Absolute Maximum Ratings” may cause permanent damage to the device.
Exposure to absolute maximum rated conditions for extended periods may affect device reliability.

ELECTRICAL CHARACTERISTICS

T_A = 25°C, unless otherwise noted.

Symbol	Parameter	Conditions	Min	Typ	Max	Unit
V _{CC}	Supply Voltage Range OIS27-12AT	Battery	8,5	13,5	15	V
V _j	Jump start voltage allowable				36	V
OL	Overload protection (output shutdown)	At T _A =20°C	50	-	-	mA
I _{CC}	Device current consumption of each channel	No load, whole voltage and temperature range		14 [28]	30 [60]	mA
I _{LOAD}	Load current (for each output)	7V < V _{CC} < 15V	1	6	20	mA
V _{OH}	Output voltage high	7V < V _{CC} < 15V	V _{CC} -1		V _{CC}	V
V _{OL}	Output voltage low	V _{CC} = 15V R _L <30kΩ	0		700	mV
R	Min detection range	I _{LOAD} =6mA	3			ms
	Max detection speed (mark width of 3mm)				1	m/s
τ	Response time	ON-OFF I _{LOAD} =6mA		20	30	us
		OFF-ON I _{LOAD} =6mA		50	100	us

MECHANICAL CHARACTERISTICS

Symbol	Parameter	Conditions	Min	Typ	Max	Unit
IP	Protection grade	-			IP67	
Out	Output configuration	-		PNP		
Lc	Length tolerance (cable 6x0.5mm ²)	-		± 20		mm

RELIABILITY PARAMETERS

Symbol	Parameter	Conditions	Value	Unit
MTTF	Mean Time To Failure	30°C-12V-mobile environment	145	Years
DC	Diagnostic	-	No	-
S	Structure	-	Fully redundant	-

MECHANICAL DIMENSIONS

The dimensions are expressed in mm, tolerance ± 0.1 mm.

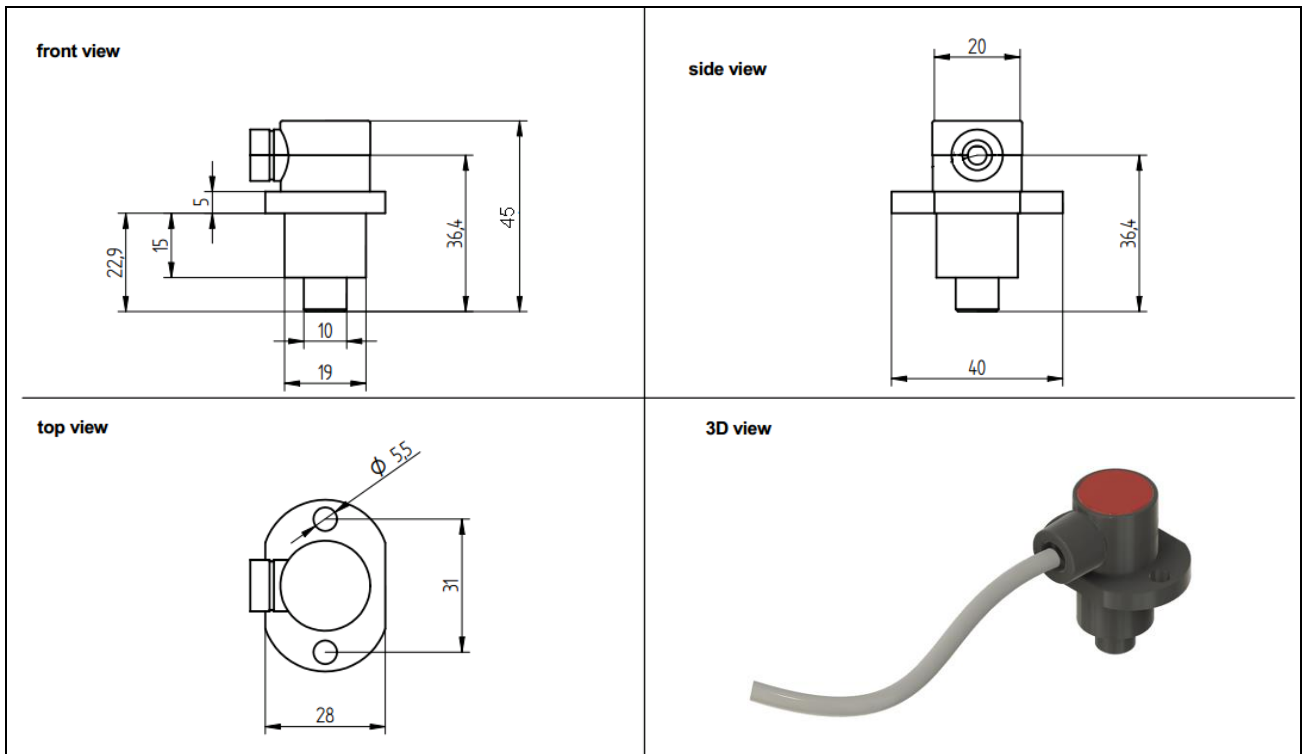

Figure 1 – Right angle version

OUTPUT CONFIGURATION

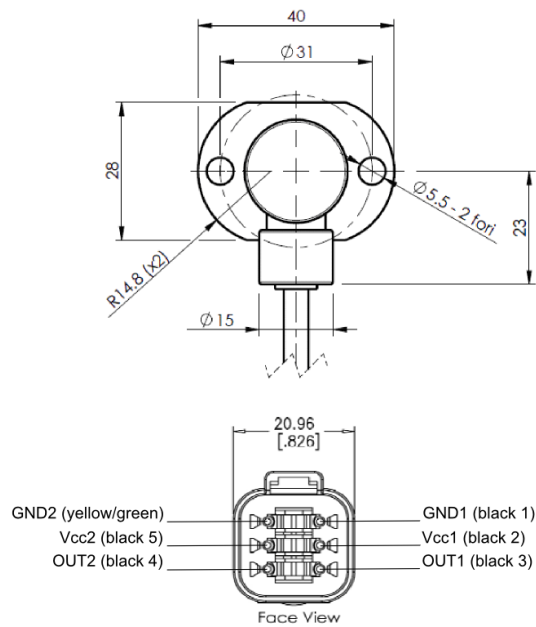

Figure 2 – ELS27-12AT configuration, Amphenol AT04-6P-MM01 connector

REGULATORY COMPLIANCE TABLE

Reference normative	Description	Test Type	Status
ISO13766 cl. 5.6	Earth moving machinery: broadband and narrowband emissions from ESA	Emission	pass
ISO13766 cl. 5.6	Earth moving machinery: immunity of ESA to electromagnetic radiation	Emission	pass
ISO13766 cl. 5.8-5.9	Immunity of ESA to electromagnetic radiated, bulk current injection, electrostatic discharge	Immunity	pass
ISO 7637-2	Road vehicles - Electrical disturbances from conduction and coupling. Part 2: Electrical transient conduction along supply lines only	Immunity	pass
ISO 16750-2	Road vehicles - Environmental conditions and testing for electrical and electronic equipment. Part 2: Electrical loads	Immunity	Pass†
EN 60529	Degrees of protection provided by enclosures	Dust and water protection	IP67

Table 1 – Compliance table ELS27-12AT

† Load Dump pulse and Cranking pulse only.

Application circuits

RESISTIVE LOAD

A typical output load is a lamp. For such resistive loads no precautions shall be taken: the output stage is protected against reverse of polarity, short circuit and temperature. The power absorbed by the output stage is equal to $R_{DSON} * I_{load}$.

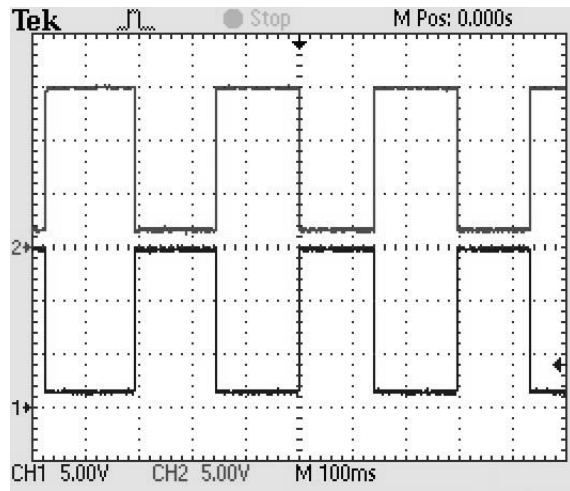
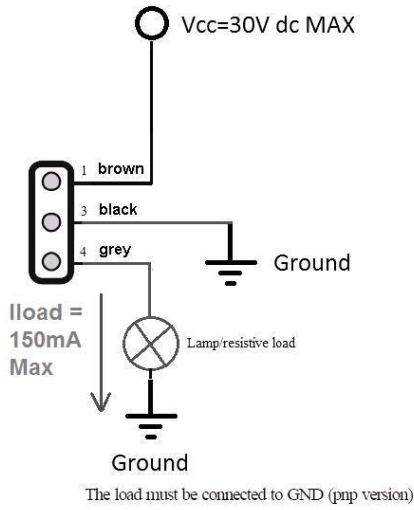

Figure 3 – Resistive load connection and $V_{OUT1} + V_{OUT2}$ transition graph

INDUCTIVE LOAD

Inductive loads are described by inductance L and resistance R. At switch ON, the inductive load causes a slow current ramp up, based on the time constant $\tau=L/R$. At switch OFF, due to inductance, the current attempts to continue to flow in the same direction, which causes the load voltage to invert.

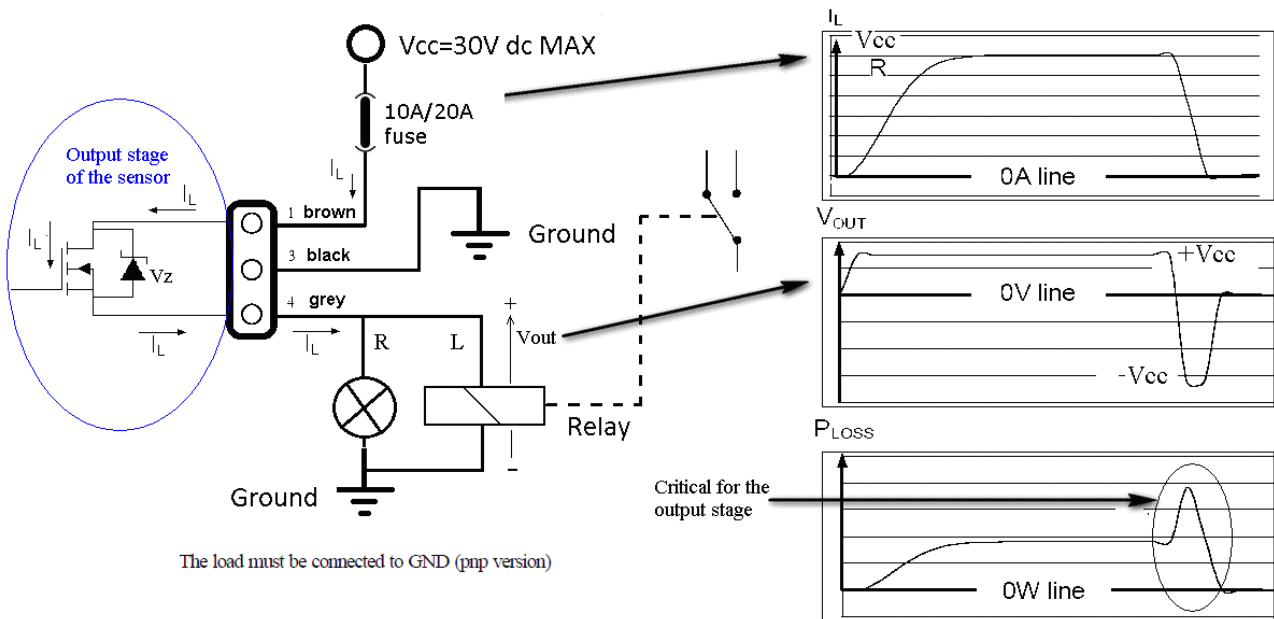

Figure 4 – Inductive load connection without protection

ELS27

In this case, depending on the supply voltage and on the time constant, there is a real risk to break the output stage of the sensor. The output stage is composed of a logic stage, a power mosfet and a zener diode: the diode protects the output against overvoltages. If the V_{DS} of the output stage during the transitory becomes very high (double the V_{CC} value) for long period, it can destroy the mosfet or the zener protection diode inside the output stage. In order to avoid this possible situation, the use of a freewheeling diode in parallel to the load is recommended.

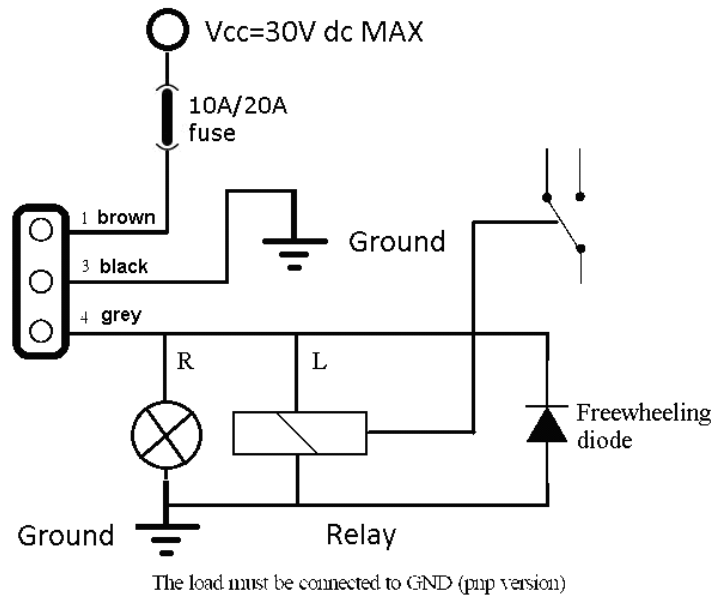
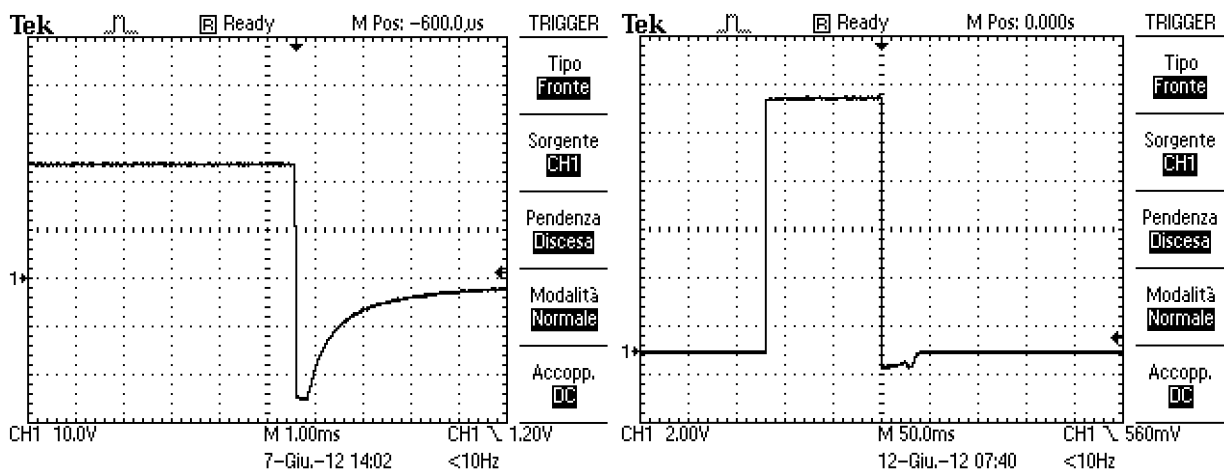
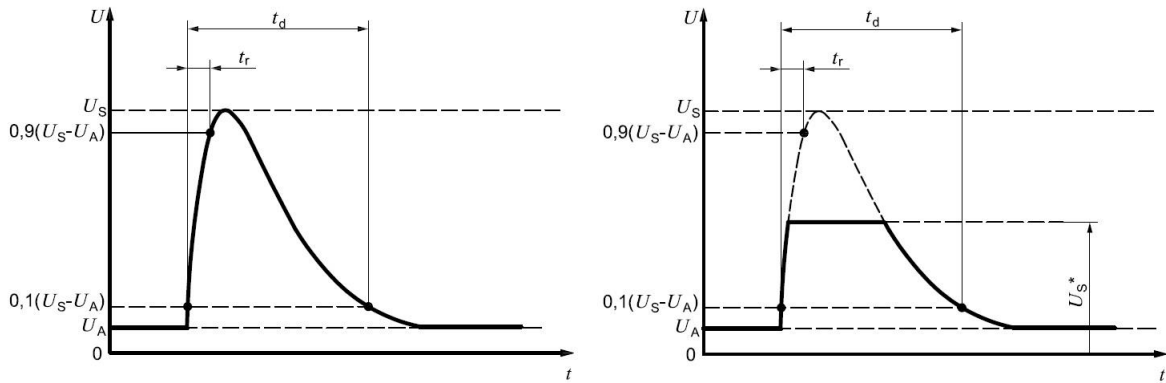

Figure 5 – Inductive load connection with protection freewheeling diode



Load dump considerations

Load dump means the disconnection of a powered load. It can cause large voltage spikes from the inductive generator(s). In automotive electronics, it refers to the disconnection of the vehicle battery from the alternator while the battery is being charged. Due to such a disconnection of the battery, other loads connected to the alternator see a surge in power line. Load dump may occur as a result of cable corrosion, poor connection or of intentional disconnection with the engine running. The pulse shape and parameters for an alternator with no centralized load dump suppression (Chap. 4.6.4 Test A ISO16750-2 2010.) are given in Figure 7 left side. The pulse shape and parameters for an alternator with centralized load dump suppression (Chap. 4.6.4 Test B ISO16750-2 2010) are given in Figure 7 right side. The ELS27 is protected against load dump disturbs (see Chap. 4.6.4 ISO16750-2 2010) at 24V: the load dump amplitude is suppressed (clamped) by the addition of two limiting devices, which preserve the electronic from these destructive pulses.



Parameter	Type of system		Minimum test requirements
	$U_N = 12\text{ V}$	$U_N = 24\text{ V}$	
U_S^a V	$79 \leq U_S \leq 101$	$151 \leq U_S \leq 202\text{ V}$	10 pulses at intervals of 1 min
R_i^a Ω	$0,5 \leq R_i \leq 4$	$1 \leq R_i \leq 8$	
t_d ms	$40 \leq t_d \leq 400$	$100 \leq t_d \leq 350$	
t_r ms	$10 \left(\frac{0}{-5} \right)$	$10 \left(\frac{0}{-5} \right)$	

^a If not otherwise agreed, use the higher voltage level with the higher value for internal resistance, or use the lower voltage level with the lower value for internal resistance.

Figure 7 – Load dump typical waveform: test A (unsuppressed) and test B (suppressed)