

General Description

ELS29 is a patented smart optical device, which is usually combined with a hydraulic steering cylinder. The main application is on rough terrain machines, to detect when the wheels are correctly aligned. The alignment occurs when the sensor detects a different refraction index zone, which is marked on the hydraulic cylinder's rod.

The product is based on reflective sensor as input stage, a computing unit (microprocessor device) and an output stage with high side driver, which can deliver up to 15mA.

The sensor includes "smart" functions and special algorithms that allow to continuously adapt the device to the wear of the system during the time, improve the life of the system, guarantee the high reliability (MTTF = 127 years) and be able to work in the harsh environment (temperature variations, rod wear, presence of electromagnetic disturbs, presence of humidity, shocks and vibrations). This serie is a miniaturized version of the ELS21 sensor and it is studied to fit in hydraulic cylinders with reduced dimensions.

Applications

Steering machines
Tilt cylinders
Multiple position control
Small cylinders control
Gearboxes

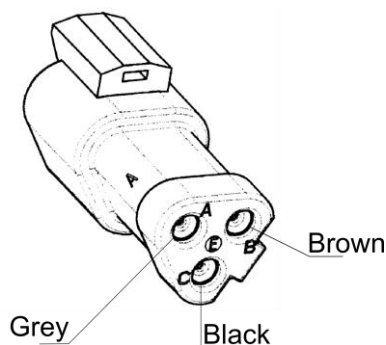

Features

- Small size, -60% of volume compared to ELS21 serie
- Integrated, tampered proof
- Unsensitive to EM noise
- Plug & play, easy installation
- MTTF = 127 years
- Smart interface and smart algorithm
- IP67

Pin Functions

OIS29

Cable color	Name	Function
Brown	V _{CC}	Power Supply
Black	GND	Ground
Grey	OUT	Output (PNP)

Ordering Information

ELS29-12AT	12V version
ELS29-24AT	24V version†

† Available only on request

ABSOLUTE MAXIMUM RATINGS

Symbol	Parameter	Min	Max	Unit
T _s	Storage Temperature	-40	85	°C
T _A	Operating Temperature Range	-20	80	°C
V _{CC}	Supply Voltage Range OIS29-12AT	8	15	V
I _o	Max output current (depending on ambient temperature)	-	20	mA

Stresses beyond those listed under "Absolute Maximum Ratings" may cause permanent damage to the device.

Exposure to absolute maximum rated conditions for extended periods may affect device reliability.

ELECTRICAL CHARACTERISTICS

T_A = 25°C, unless otherwise noted.

Symbol	Parameter	Conditions	Min	Typ	Max	Unit
V _{CC}	Supply Voltage Range OIS29-12AT	Battery	8	13,5	15	V
OL	Overload protection (output shutdown)	8V < V _{CC} < 14V	-	-	160	mA
I _{CC}	Device current consumption	No load, V _{CC} =13,5V	-	11	15	mA
I _{LOAD}	Load current	13,5V, 10kΩ	-	1,2	-	mA
		13,5V, 4,7kΩ	-	2,4	-	mA
V _{OH}	Output voltage high	8V < V _{CC} < 14V, no load	V _{CC} -0.7	-	-	V
V _{OL}	Output voltage low	V _{CC} = 13,5V R _L <10kΩ	0	10	50	mV
R	Min detection range	I _{LOAD} =2,4mA	3			ms
	Max detection speed (mark width of 3mm)				1	m/s
τ	Response time	ON-OFF I _{LOAD} =2,4mA		30	30	us
		OFF-ON I _{LOAD} =2,4mA		0,3	-	us
t _{start}	Start-up time		520	-	550	ms

MECHANICAL CHARACTERISTICS

Symbol	Parameter	Conditions	Min	Typ	Max	Unit
IP	Protection grade	-			IP67	
Out	Output configuration	-		PNP		
Lc	Length tolerance (cable 3x0.5mm ²)	-		± 20		mm

RELIABILITY PARAMETERS

Symbol	Parameter	Conditions	Value	Unit
MTTF	Mean Time To Failure	30°C-12V-mobile environment	127	Years

MECHANICAL DIMENSIONS

The dimensions are expressed in mm, tolerance ± 0.1 mm.

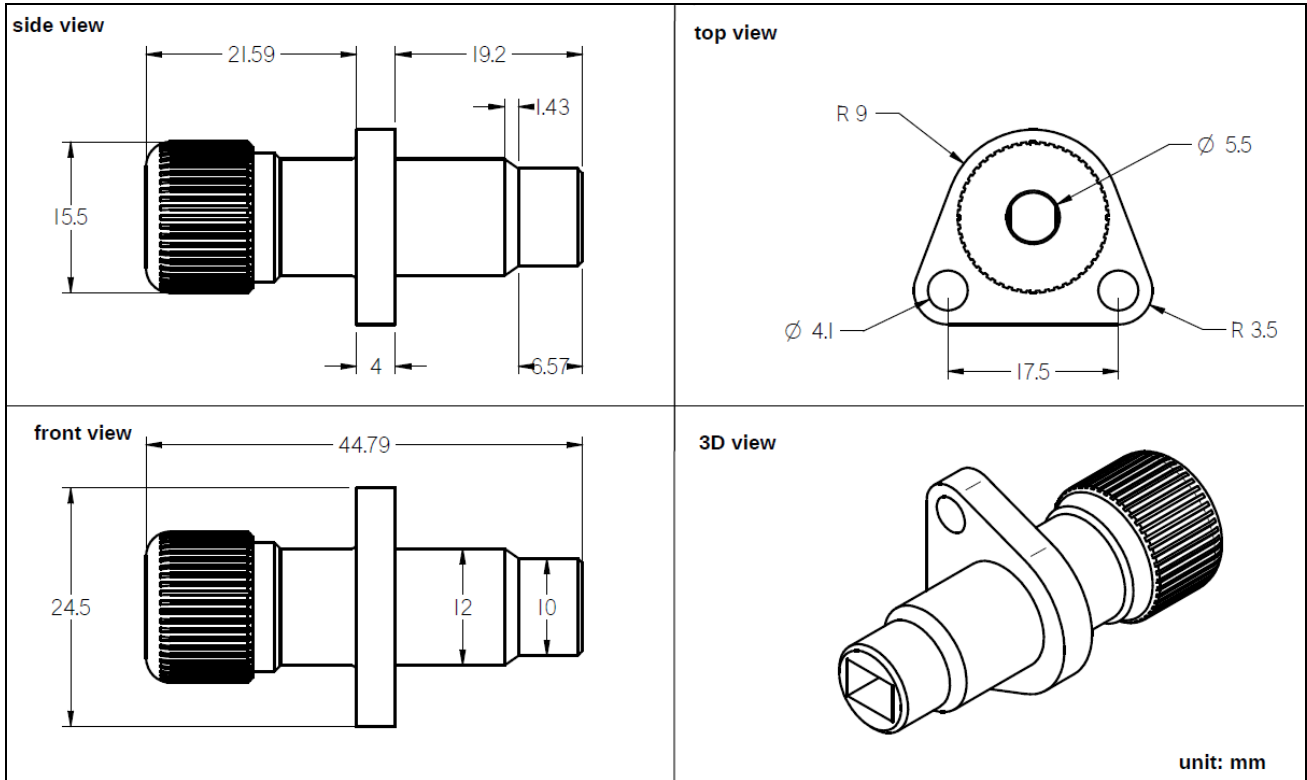

Figure 1 – ELS29-12AT mechanical dimensions

OUTPUT CONFIGURATION

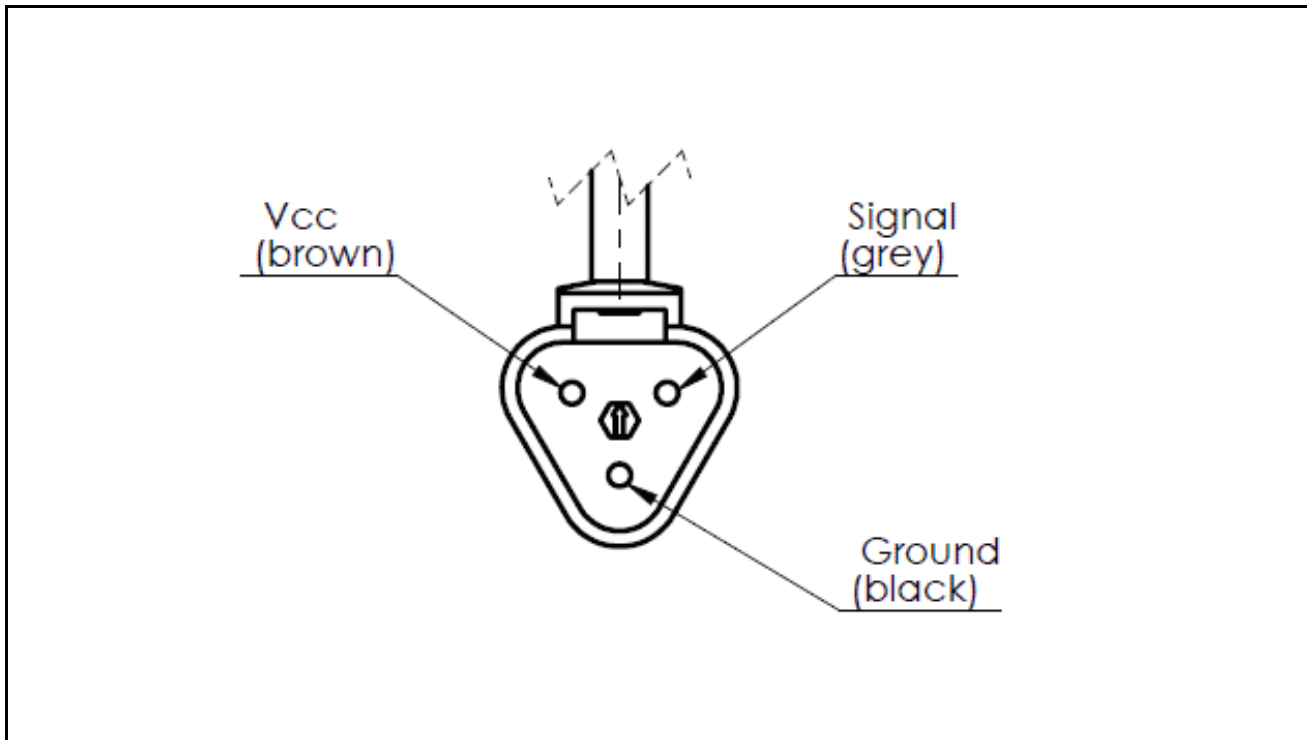

Figure 2 – ELS29-12AT configuration

REGULATORY COMPLIANCE TABLE OIS29-12AT

Reference normative	Description	Test Type	Status
ISO13766 cl. 5.6	Earth moving machinery: broadband and narrowband emissions from ESA	Emission	pass
ISO13766 cl. 5.6	Earth moving machinery: immunity of ESA to electromagnetic radiation	Emission	pass
ISO13766 cl. 5.8-5.9	Immunity of ESA to electromagnetic radiated, bulk current injection, electrostatic discharge	Immunity	pass
ISO 7637-2	Road vehicles - Electrical disturbances from conduction and coupling. Part 2: Electrical transient conduction along supply lines only	Immunity	pass
ISO 16750-2	Road vehicles - Environmental conditions and testing for electrical and electronic equipment. Part 2: Electrical loads	Immunity	Pass‡
EN 60529	Degrees of protection provided by enclosures	Dust and water protection	IP67

Table 1 – Compliance table ELS29-12AT

APPLICATION CIRCUIT

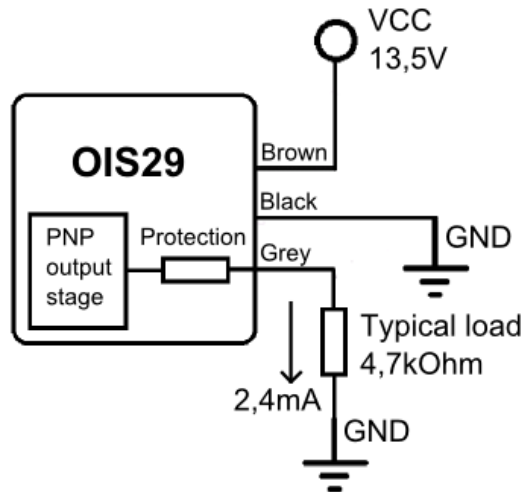

Figure 3 – Resistive load connection

‡ Load Dump pulse and Cranking pulse only.

Load dump considerations

Load dump means the disconnection of a powered load. It can cause large voltage spikes from the inductive generator(s). In automotive electronics, it refers to the disconnection of the vehicle battery from the alternator while the battery is being charged. Due to such a disconnection of the battery, other loads connected to the alternator see a surge in power line.

Load dump may occur as a result of cable corrosion, poor connection or of intentional disconnection with the engine running. The pulse shape and parameters for an alternator with no centralized load dump suppression (Chap. 4.6.4 Test A ISO16750-2 2010.) are given in Figure 7 left side. The pulse shape and parameters for an alternator with centralized load dump suppression (Chap. 4.6.4 Test B ISO16750-2 2010) are given in Figure 7 right side.

The ELS29 is protected against load dump disturbs (see Chap. 4.6.4 ISO16750-2 2010) at 12V: the load dump amplitude is suppressed (clamped) by the addition of two limiting devices, which preserve the electronic from these destructive pulses.

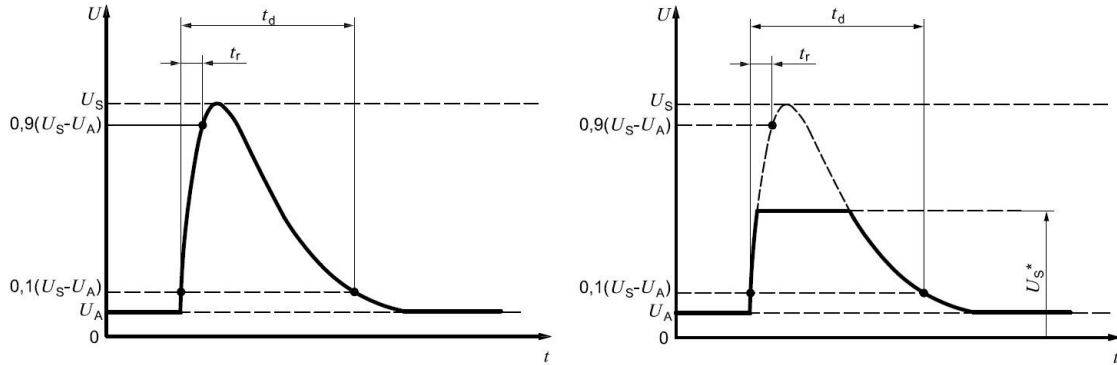

Parameter	Type of system		Minimum test requirements
	$U_N = 12\text{ V}$	$U_N = 24\text{ V}$	
U_S^a V	$79 \leq U_S \leq 101$	$151 \leq U_S \leq 202\text{ V}$	10 pulses at intervals of 1 min
R_i^a Ω	$0,5 \leq R_i \leq 4$	$1 \leq R_i \leq 8$	
t_d ms	$40 \leq t_d \leq 400$	$100 \leq t_d \leq 350$	
t_r ms	$10 \left(\frac{0}{-5} \right)$	$10 \left(\frac{0}{-5} \right)$	

^a If not otherwise agreed, use the higher voltage level with the higher value for internal resistance, or use the lower voltage level with the lower value for internal resistance.

Figure 4 – Load dump typical waveform: test A (unsuppressed) and test B (suppressed)